



HYDROFIRE ΕΠΕ

Buildings - Industry - Marine – Waterworks

END OF AG. PANTELEIMONOS Str. (ELEONAS)

GR-12241 EGALEO,

Tel.: +30 210 3412 749-750 Fax: +30 210 3412 406

www.hydrofire.gr, email: info@hydrofire.gr



MONITOR - MG 413 (CARBON STEEL, HOT DIP GALVANIZED)



TECHNICAL DATA

MODEL	MG 413
NOMINAL SIZE	4 Inch (100 MM)
MAX. SERVICE PRESSURE	175 PSI (12 Bar)
MAXIMUM FLOW	1250 GPM (4730 LPM)
FACTORY HYDROSTATIC TEST PRESSURE	35 Bar (500 PSI)
SWIVEL JOINT	Bronze to IS 318 / ASTM B62 with double row of Stainless Steel Ball Bearing and Grease Fittings
NOZZLE THRUST REACTION IN Kg.	Flow in LPM X $\sqrt{\text{Pressure}}$ in Kg./sq.cm. X 0.0228
INLET CONNECTION	4" OR 6" (100 NB OR 150 NB) Flange to ANSI B16.5 # 150, R.F.
OUTLET CONNECTION	4" BSP
MONITOR ELEVATION	90 Deg. above horizontal & 45 Deg. below horizontal
MONITOR ROTATION	360 Deg. continuous
MONITOR MOVEMENT	Hand wheel driven fully enclosed worm gear
FINISH	Red to RAL 3001
WEIGHT (Approx)	76 Kg
ORDERING INFORMATION	Specify Monitor Model and Inlet Flange Size
APPROVAL	FM Approved



of stainless steel ball bearing. Both vertical and horizontal movements are controlled with hand wheel driven fully enclosed worm gears and protected from the elements.

The monitor has large flow capability and can be manually operated by a single fire fighter. The design ensures to prevent jet reaction forces from effecting the horizontal and the vertical position of the monitor. The counter balance is not required to offset the weight of the nozzle. The monitor has the ability for 360 deg. continuous horizontal rotation and angle of elevation from 90 deg. above horizontal to 45 deg. below horizontal.

The water vanes in discharge tube reduces the turbulence and friction loss, thus increasing the nozzle performance to achieve greater range. To ensure desired performance, the friction loss through monitor must be considered while selecting the nozzle and the flow through the monitor with reference to available base pressure at inlet of the monitor. For flow and jet reach data refer monitor nozzle data sheet.

DESCRIPTION

Monitor Model- MG 413 is durable manual controlled monitor for fixed installation as well as trailer mounted unit. The monitor is generally used for protection of flammable liquid storage tanks, loading racks, dykes marine and many other Industrial application.

The Monitor possess several design features that provides ease of operation, minimum maintenance and resistance to normally destructive environments. The monitor is used with aspirating, non-aspirating and water nozzles with flow range upto 1250 GPM (4730 LPM).

The monitor has welded carbon steel 4 inch (100 MM) water way. All steel parts are hot dip galvanized and epoxy painted for excellent corrosion resistance. The vertical and horizontal rotation is through corrosion resistant bronze swiveling joints with double row



HYDROFIRE ΕΠΕ

Buildings - Industry - Marine – Waterworks

END OF AG. PANTELEIMONOS Str. (ELEONAS)

GR-12241 EGALEO,

Tel.: +30 210 3412 749-750 Fax: +30 210 3412 406

www.hydrofire.gr, email: info@hydrofire.gr



INSTALLATION, TESTING AND MAINTENANCE

The monitor must be installed and operated carefully by a trained person, having good knowledge of equipment. Before assembly of the monitor to the supply piping, thoroughly flush the piping with water to avoid sand, residue, welding slag or other debris hindering the proper functioning of the monitor.

After few initial successful tests, an authorized person must be trained to perform the inspection and testing of the monitor.

The monitor should be ready for use. To achieve this condition, scheduled inspection and maintenance operation should be performed and it must be recorded in the maintenance register book indicating the requirement or recommendation. The recommended maintenance, procedure must be followed as given in the manual and also as per the local authority having jurisdiction.

It is recommended to carry out weekly physical inspection of the monitor. The inspection should verify that no damage has taken place to any component and the monitor is ready for use.

Carry out functional test every month for the flow, regular rotation in horizontal and vertical plane for the entire operating range to observe any leakage.

Periodic proper greasing through grease nipple provided on bearing, worm wheel and worm shaft must be ensured. Use water resistant low friction synthetic grease. Lubrication is required for smooth operation.

Each monitor must be operated with the full flow in accordance to the guidelines of the organisation having local jurisdiction.

The owner is responsible for maintaining the equipment in proper operating condition.

CAUTION

A trained personnel for fire fighting must use the monitor. Appropriate guidance & training must be given to reduce the risk or injury.

The nozzle must be fixed to the monitor carefully, The flange bolts must be tightened uniformly.

The piping must be able to withstand the horizontal reaction force. Serious injury to personnel and equipment can result from improper installation.

When installing monitor it is critical that flange bolts be tightened uniformly to prevent cocking of the monitor relative to the flange or valve.

Before flowing water from monitor, check that all personnel are out of stream path and stream direction will not cause avoidable property damage.

Application of water or foam on an electric appliance can cause serious injury.

The water supply to monitor must be increased / decreased gradually to prevent possible water hammer occurrence.



HYDROFIRE ΕΠΕ

Buildings - Industry - Marine – Waterworks

END OF AG. PANTELEIMONOS Str. (ELEONAS)

GR-12241 EGALEO,

Tel.: +30 210 3412 749-750 Fax: +30 210 3412 406

www.hydrofire.gr, email: info@hydrofire.gr

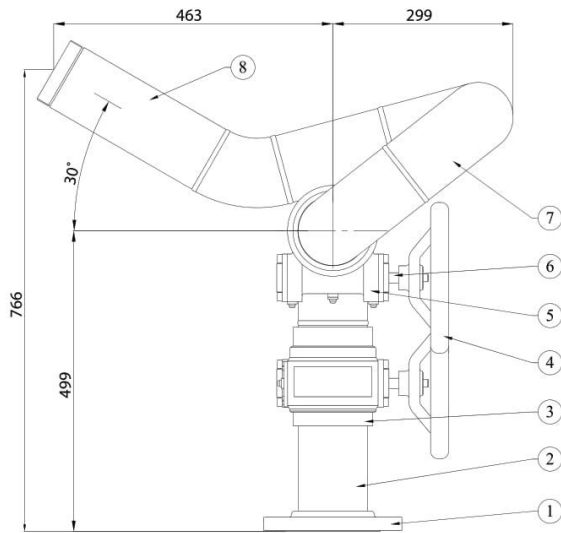

ELEVATION

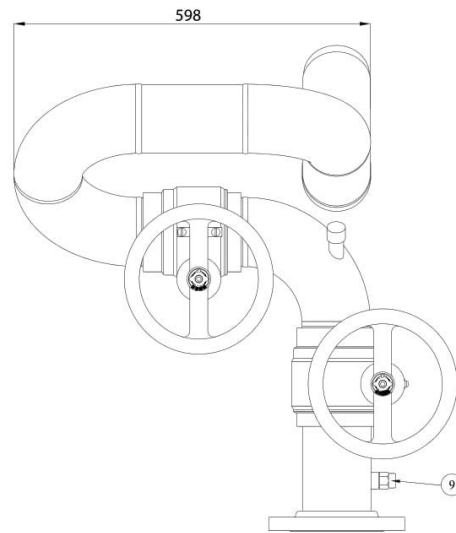

SIDE VIEW

PART LIST

SR.NO	DESCRIPTION	MATERIAL SPECIFICATION
1	BASE FLANGE	ASTM A105
2	INLET PIPE	ASTM A106 SCH 40
3	SWIVEL JOINT	BRONZE IS:318/ ASTM B62
4	HANDLE WHEEL	CAST IRON
5	WORM WHEEL	BRONZE IS:318/ ASTM B62
6	WORM SHAFT	STAINLESS STEEL
7	ELBOW	ASTM A234 WPB SCH40
8	BARREL PIPE	ASTM A106 SCH 40
9	DRAIN VALVE	BRASS

Note :

- 1) Monitor inlet flange standard size is 80NB (3") to ANSI B16.5, 150#, Other sizes 65NB (2.5") or 100NB (4") are optional.
- 2) All dimensions in mm and are approximate.
- 3) As the Monitor is hot dip galvanized, flange will be RF without serration.