



HYDROFIRE ΕΠΕ

Buildings - Industry - Marine – Waterworks
END OF AG. PANTELEIMONOS Str. (ELEONAS)
GR-12241 EGALEO,

Tel.: +30 210 3412 749-750 Fax: +30 210 3412 406
www.hydrofire.gr, email: info@hydrofire.gr



Mechanical
pressure measurement

Bourdon tube pressure gauge Model 213.53, liquid filling, stainless steel case

WIKA data sheet PM 02.12



for further approvals
see page 2

Applications

- For measuring points with high dynamic pressure loads or vibrations
- For gaseous and liquid media that are not highly viscous or crystallising and will not attack copper alloy parts
- Hydraulics
- Compressors, shipbuilding

Special features

- Vibration and shock resistant
- Especially sturdy design
- NS 63 and 100 with German Lloyd and Gosstandart approval
- Scale ranges up to 0 ... 1,000 bar



Bourdon tube pressure gauge, model 213.53.100,
lower mount

Description

Design
EN 837-1

Nominal size in mm
50, 63, 100

Accuracy class
NS 50, 63: 1.6
NS 100: 1.0

Scale ranges
NS 50: 0 ... 1 to 0 ... 400 bar
NS 63, 100: 0 ... 0.6 to 0 ... 1,000 bar
or all other equivalent vacuum or combined pressure and vacuum ranges

Pressure limitation

NS 50, 63:	Steady:	3/4 x full scale value
	Fluctuating:	2/3 x full scale value
	Short time:	Full scale value
NS 100:	Steady:	Full scale value
	Fluctuating:	0.9 x full scale value
	Short time:	1.3 x full scale value

Permissible temperature

Ambient: -20 ... +60 °C
Medium: +60 °C maximum

Temperature effect

When the temperature of the measuring system deviates from the reference temperature (+20 °C):
Max. ± 0.4 %/10 K of the span

Ingress protection

IP 65 per EN 60529 / IEC 60529



HYDROFIRE ΕΠΕ

Buildings - Industry - Marine – Waterworks
END OF AG. PANTELEIMONOS Str. (ELEONAS)
GR-12241 EGALEO,

Tel.: +30 210 3412 749-750 Fax: +30 210 3412 406
www.hydrofire.gr, email: info@hydrofire.gr



Standard version

Process connection

Copper alloy,
lower mount (LM) or back mount (BM),
NS 50, 63: G ¼ B (male), 14 mm flats
NS 100: G ½ B (male), 22 mm flats

Pressure element

NS 50:
Copper alloy, C-type or helical type

NS 63:
≤ 400 bar: Copper alloy, C-type or helical type
> 400 bar: Stainless steel 316L, helical type

NS 100:
< 100 bar: Copper alloy, C-type
≥ 100 bar: Stainless steel 316L, helical type

Movement

Copper alloy

Dial

NS 50, 63: Plastic ABS, white, with pointer stop pin
NS 100: Aluminium, white, black lettering

Pointer

NS 50, 63: Plastic, black
NS 100: Aluminium, black

Window

Plastic, crystal-clear

Case

Natural finish stainless steel, with blow-out device with
NS 50: in case back, 12 o'clock
NS 63, 100: at case circumference, 12 o'clock
O-ring seal between case and connection.
Scale ranges ≤ 0 ... 16 bar with compensating valve to vent case.

Bezel ring

Crimp ring, glossy finish stainless steel, triangular bezel

Filling liquid

Glycerine

Options

- Other process connection
- Sealings (model 910.17, see data sheet AC 09.08)
- Measuring system and movement from stainless steel (model 233.53)
- NS 100: Zero adjustment (in front)
- Increased medium temperature with special soft solder
 - NS 50, 63: 100 °C
 - NS 100: 150 °C
- Ambient temperature resistant -40 ... +60 °C with silicone oil filling
- NS 50: Higher scale ranges up to 0 ... 1,000 bar
- Panel mounting flange, stainless steel, for back connection
- Surface mounting flange, stainless steel (not NS 50)
- Mounting clamp (for back connection)

CE conformity

Pressure equipment directive

97/23/EC, PS > 200 bar, module A, pressure accessory

Approvals

- GL, ships, shipbuilding (e.g. offshore), Germany
- EAC, import certificate, customs union Russia/Belarus/Kazakhstan
- GOST, metrology/measurement technology, Russia
- KBA, automotive, European Community
- CRN, safety (e.g. electr. safety, overpressure, ...), Canada

Certificates ¹⁾

- 2.2 test report per EN 10204 (e.g. state-of-the-art manufacturing, material proof, indication accuracy)
- 3.1 inspection certificate per EN 10204 (e.g. indication accuracy)

1) Option

Approvals and certificates, see website

Dimensions in mm

Standard version

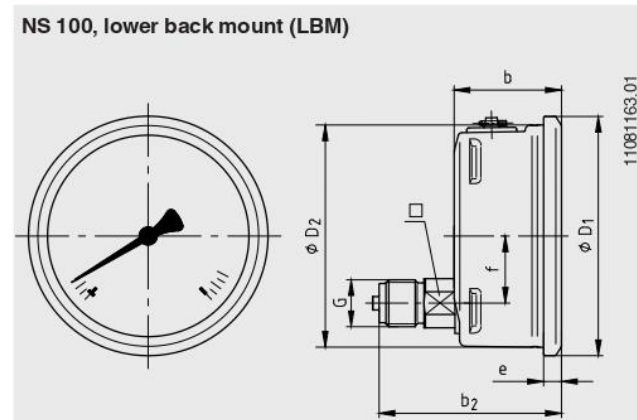
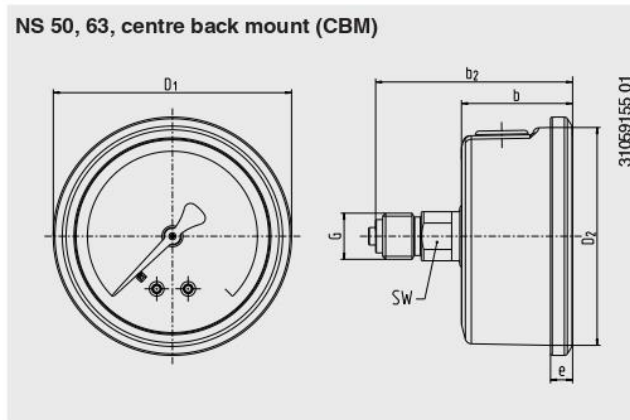
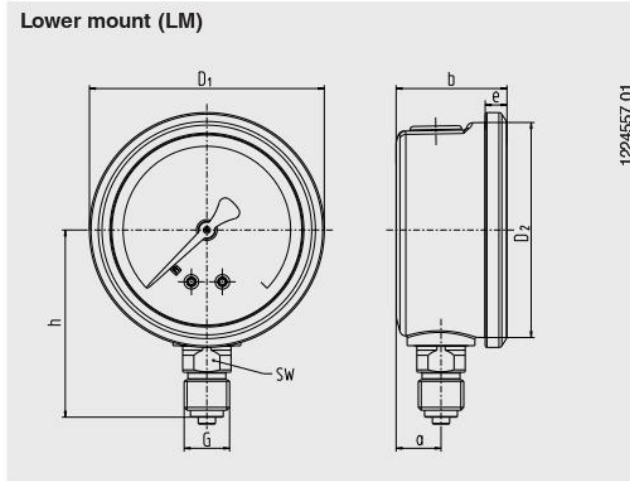

NS	Dimensions in mm										Weight in kg
	a	b ±0.5	b ₂ ±0.5	D ₁	D ₂	e	f	G	h ±1	SW	
50	12	30	55	55	50	5.5	-	G ¼ B	48	14	0.15
63	13	32	56	68	62	6.5	-	G ¼ B	54	14	0.21
100	15.5	48	81.5	107	100	8	30	G ½ B	87	22	0.80

Process connection per EN 837-1 / 7.3

Ordering information

Model / Nominal size / Scale range / Connection size / Connection location / Options

© 2008 WIKA Alexander Wiegand SE & Co. KG, all rights reserved.
 The specifications given in this document represent the state of engineering at the time of publishing.
 We reserve the right to make modifications to the specifications and materials.