



HYDROFIRE ΕΠΕ

Buildings - Industry - Marine – Waterworks
 END OF AG. PANTELEIMONOS Str. (ELEONAS)
 GR-12241 EGALEO,
 Tel.: +30 210 3412 749-750 Fax: +30 210 3412 406
 www.hydrofire.gr, email: info@hydrofire.gr



— MODEL — X43H

H Style Strainer



- Low Pressure Drop
- Ductile Iron with NSF/ANSI 61 Fusion Bonded Epoxy Coating Construction with a 316 Stainless Steel Strainer
- Large Flow Area H-Style Design
- Service Without Removal From Line

The Cla-Val Model X43H Strainer offers an effective means of removing unwanted solid particles in pipeline flow. These strainers are ideal for preventing fouling, debris and particle buildup in Cla-Val Automatic Control Valves. The large flow area design, with a flat stainless steel strainer mesh perpendicular to flow, is optimized for low pressure drop applications.

Optional accessories that can be added to the X43H Strainer include the Differential Pressure Switch and the X141DP Differential Pressure Gauge Assembly.

Maintenance is fast and easy with the compact H-pattern, requiring only top cover removal. Though the strainer may be installed in any position, installation with the cover up is recommended.

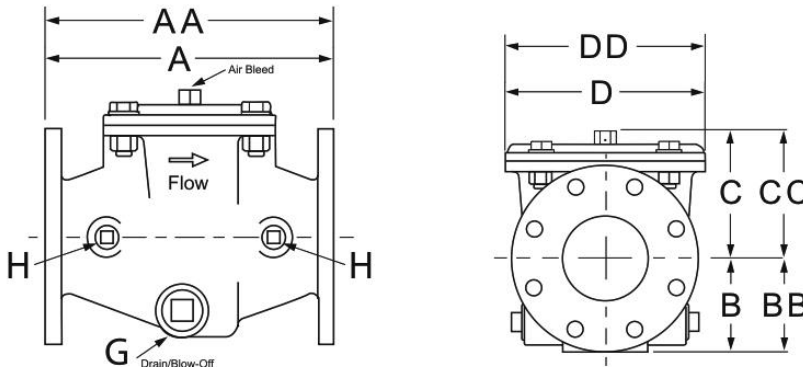

Dimensions

Strainer Size (inches)	1 ½	2	2 ½	3	4	6	8	10	12	14	16	18	20	24	30	36	48
A 150 ANSI	9.06	9.06	9.06	11.81	11.81	15.75	19.69	22.83	24.02	25.59	31.50	31.50	37.40	43.31	45.27	45.67	45.67
AA 300 ANSI	—	9.13	9.13	11.89	11.89	15.83	19.76	22.91	24.09	25.67	31.57	31.57	37.48	43.39	—	—	—
B 150 ANSI	2.50	3.26	3.66	4.06	4.33	5.63	6.69	8.40	9.40	10.24	12.20	13.18	19.09	19.09	22.49	26.00	34.00
BB 300 ANSI	—	3.26	3.66	4.06	5.02	5.63	7.50	8.86	10.20	10.94	12.70	15.00	19.09	19.09	—	—	—
C Max. 150 ANSI	3.78	3.78	3.78	5.91	5.91	7.52	8.82	11.61	15.16	14.96	19.69	19.69	23.98	23.98	25.10	36.20	34.11
CC Max. 300 ANSI	—	5.20	5.35	6.22	6.22	7.99	9.33	12.79	15.67	15.67	19.69	19.69	23.98	23.98	—	—	—
D Dia. 150 ANSI	7.87	7.87	7.87	9.25	9.25	15.74	18.11	22.05	26.77	26.77	35.43	35.43	46.85	46.85	46.85	61.65	61.65
DD Dia. 300 ANSI	—	7.99	7.99	9.37	9.37	15.86	18.23	22.17	26.85	26.85	35.43	35.43	46.85	46.85	—	—	—
H Inlet/Outlet Plugs NPT	½	½	½	½	½	½	½	½	½	½	½	½	½	½	½	½	½
G Drain/Blow-off Plug NPT	1¼	1¼	1¼	1¼	1¼	1¼	1¼	1¼	2	2	2	2	2	2	2	2	2
Approx. Ship Wt. Lbs.	33	36	39	59	73	143	212	432	626	683	970	1073	1175	1962	2249	4123	4828

Strainer Size (mm)	40	50	65	80	100	150	200	250	300	350	400	450	500	600	750	900	1200
A 150 ANSI	230	230	230	300	300	400	500	580	610	650	800	800	950	1100	1150	1160	1160
AA 300 ANSI	—	232	232	302	302	402	502	582	612	652	802	802	952	1102	—	—	—
B 150 ANSI	64	83	93	103	110	143	170	213	240	260	310	335	485	485	571.5	660.5	862.5
BB 300 ANSI	—	83	93	103	128	143	191	225	259	278	321	380	485	486	—	—	—
C Max. 150 ANSI	96	96	96	150	150	191	224	295	385	380	500	500	609	609	637.5	919.5	866.5
CC Max. 300 ANSI	—	132	136	158	158	203	237	325	398	398	500	500	609	609	—	—	—
D Dia. 150 ANSI	200	200	200	235	235	400	460	560	680	680	900	900	1190	1190	1190	1566	1566
DD Dia. 300 ANSI	—	203	203	238	238	403	463	563	682	682	900	900	1190	1190	—	—	—
H Inlet/Outlet Plugs NPT	½	½	½	½	½	½	½	½	½	½	½	½	½	½	½	½	½
G Drain/Blow-off Plug NPT	1¼	1¼	1¼	1¼	1¼	1¼	1¼	1¼	2	2	2	2	2	2	2	2	2
Approx. Ship Wt. (kg)	15	16	18	27	33	65	96	196	284	310	440	600	810	890	1020	1870	2190



HYDROFIRE ΕΠΕ

Buildings - Industry - Marine – Waterworks

END OF AG. PANTELEIMONOS Str. (ELEONAS)

GR-12241 EGALEO,

Tel.: +30 210 3412 749-750 Fax: +30 210 3412 406

www.hydrofire.gr, email: info@hydrofire.gr



Specifications

Sizes (Inches):	1½, 2, 2½, 3, 4, 6, 8, 10, 12, 14, 16, 18, 20, 24, 30, 36 and 48
Sizes (mm):	40, 50, 65, 80, 100, 150, 200, 250, 300, 350, 400, 450, 500, 600, 750, 900, 1200
Ends:	Flanged, ANSI Class 150 and 300 (Note: 300# Flanges are Raised Face)
Max Pressure Rating:	150# - 250 psi • 300# - 400 psi
Temperature:	Maximum 175°F
Materials:	
Body & Cover:	Ductile Iron ANSI B16.42; Fusion Bonded Epoxy Coating Standard
Cover Seal:	Buna-N® Synthetic Rubber
Strainer:	316 Stainless Steel; Ductile Iron, Epoxy Coated Frame
Strainer Mesh Sizes:	Standard 10 mesh / 2000 Micron / Openings 0.078 inch • Optional .039 and .059 inch openings available
Drain/Blow-Off:	Connection furnished with Standard Stainless Steel Plug
Cover Fasteners:	Stainless Steel

Model X43H Flow Chart

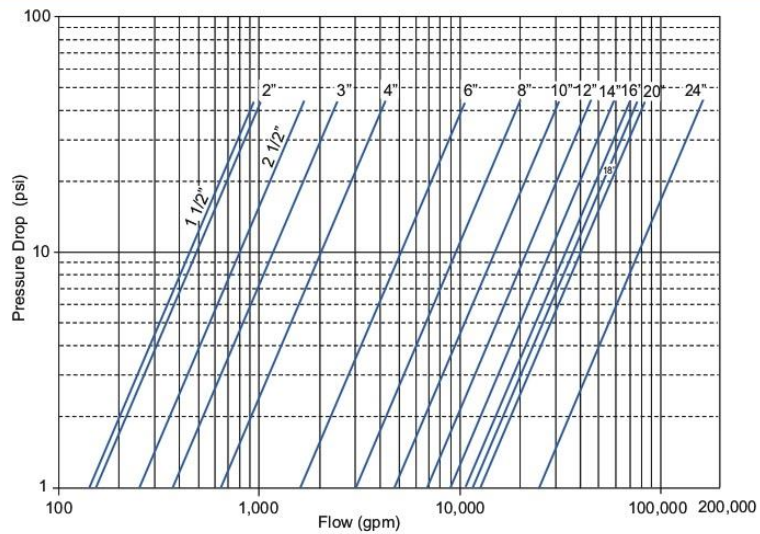

C_v Factor

Size (inches)	1 ½	2	2 ½	3	4	6	8	10	12	14	16	18	20	24	*30	*36	*48
Size (millimeters)	40	50	65	80	100	150	200	250	300	350	400	450	500	600	750	900	1200
C _v (Gal/Min. - gpm.)	96	150	254	367	654	1644	3922	4566	6800	8949	11692	12796	18264	26302	CF	CF	CF
C _v (Litres/Sec - l/s.)	23	36	61	88	157	395	942	1097	1634	2150	2809	3074	4388	6319	CF	CF	CF

C_v in gpm = gpm @ 1psid head loss • C_v in l/s = l/s @ 1bar head loss

*Consult factory to confirm flow data for 30-inch/750mm and larger strainers

Model X43H Strainer Typical Application



Strainer Options

