



HYDROFIRE ΕΠΕ

Buildings - Industry - Marine – Waterworks
END OF AG. PANTELEIMONOS Str. (ELEONAS)
GR-12241 EGALEO,
Tel.: +30 210 3412 749-750 Fax: +30 210 3412 406
www.hydrofire.gr, email: info@hydrofire.gr



BRAIDED LOOP JOINTS (U-TYPE)



Scan this QR Code



The loop joint is designed to move in any direction making it a simple, all-in-one joint for a variety of applications. There's no limit to the seismic applications that loop joints can handle. It can even be designed with lined hose for high velocity, double-braid for high pressures, and all stainless steel construction for media compatibility.

Loop Joint use for Seismic Protection

Piping used in applications and locations subject to seismic conditions have their own set of unexpected random movements and greater costs to overcome. The random motion common to earthquakes requires that seismic expansion joints be capable of movement in any direction. Of the 6 possible directions. Ayvaz Loopjoint's orientation can be changed relative to the piping, further minimizing the likelihood of compressive movement.

Advantages of Braided Loop, Seismic Expansion Joints

- Loop joint offers significant cost and safety benefits not found in comparable seismic expansion joints
- FM approval for the safety features to be used at fire protection pipelines.
- Bellows design according to EJMA coding system.
- Construction according to EN14917 standard.
- Large lateral movements by single expansion joint

Application Areas

- Fire Protection pipe lines
- HVAC pipe lines
- Industrial process & applications
- Power generation & Energy plants

DESIGN (EN 14917)

Bellow Material	Stainless Steel AISI 304 (opt.321,316L,316Ti,309)
Braiding Material	Stainless Steel AISI 304
Connection Types	Floating Flanged, Welded Ended, Grooved & Threaded
Flange Material	PN 16, St.37.2 as standard, the material can be customised on request
Certificates	FM approval, Class 1920 Material certificate 3.1 according to EN 10204 and /or ASME

Operation Conditions

Operating Temperature	-10°C/+550°C
Operating Pressure	175 psi & 250 psi Can be produced with different pressure rates

Important

For detailed information, get in contact with Ayvaz's expert sales team.
We strongly advise against the use of expansion joints and bellows for misalignment.



HYDROFIRE EPE

Buildings - Industry - Marine – Waterworks
 END OF AG. PANTELEIMONOS Str. (ELEONAS)
 GR-12241 EGALEO,
 Tel.: +30 210 3412 749-750 Fax: +30 210 3412 406
www.hydrofire.gr, email: info@hydrofire.gr



BRAIDED LOOP JOINTS (U-TYPE)

U-Flex, Braided Loop Joints, Flanged Connection

Available Types (Standard Versions)

U-type, Braided Loop-joint with Rotating Flanges		
Name	Movement in all planes	Design
U-Flex	±40mm (1,5") ±100mm (4") ±200mm (8")	175/250psi

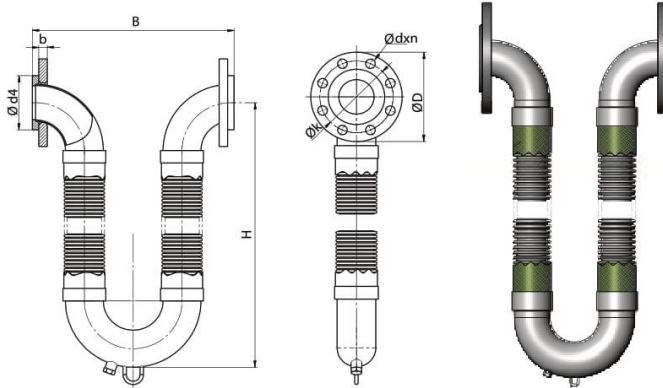

Flange (DIN EN 1092/1) PN 16						
DN	ØD	Øk	Ød4	f	b	Ød4xn
DN25	115	85	68	2	16	Ø 14x4
DN32	140	100	78	2	18	Ø 18x4
DN40	150	110	88	3	18	Ø 18x4
DN50	165	125	102	3	20	Ø 18x4
DN65	185	145	122	3	20	Ø 18x4
DN80	200	160	138	3	20	Ø 18x8
DN100	220	180	158	3	22	Ø 18x8
DN125	250	210	188	3	22	Ø 18x8
DN150	285	240	212	3	24	Ø 23x8
DN200	340	295	268	3	26	Ø 23x12
DN250	405	355	320	3	29	Ø 27x12
DN300	460	410	378	4	32	Ø 27x12

Alternative flange dimensions are also possible e.g. according to US standards (ANSI), JIS etc.

Size		Layer of Braiding		Ødi	s	R	1,5" movement (40mm)-175 PSI				4" movement (100mm)-175 PSI			
DN	inch	175 psi	250 psi				B	H	Lh	Code	B	H	Lh	Code
DN25	1"	1 ply	2 ply	33,7	2,6	38	222	380	287	702.080.303.030	324	510	417	702.080.303.035
DN32	1¼"	1 ply	2 ply	42,4	2,6	47,5	260	410	294	702.080.303.040	343	535	419	702.080.303.045
DN40	1½"	1 ply	2 ply	48,3	2,6	57	300	435	297	702.080.303.050	362	585	447	702.080.303.055
DN50	2"	1 ply	2 ply	60,3	2,9	76	375	485	303	702.080.303.060	426	635	453	702.080.303.065
DN65	2½"	1 ply	2 ply	76,1	2,9	95	450	535	307	702.080.303.070	450	715	487	702.080.303.075
DN80	3"	1 ply	2 ply	88,9	3,2	114	536	585	313	702.080.303.080	536	765	490	702.080.303.085
DN100	4"	1 ply	2 ply	114,3	3,6	152	680	715	354	702.080.303.090	680	890	529	702.080.303.095
DN125	5"	1 ply	2 ply	140	4	190	832	815	365	702.080.303.100	832	1020	570	702.080.303.105
DN150	6"	1 ply	2 ply	168,3	4,5	229	988	940	398	702.080.303.110	988	1170	628	702.080.303.115
DN200	8"	2 ply	3 ply	219	6	305	1292	1220	500	702.080.303.120	1292	1475	756	702.080.303.125
DN250	10"	2 ply	3 ply	273,0	6,3	381	1600	1400	502	702.080.303.130	1600	1702	804	702.080.303.135

* All dimensions given in the tables are in "mm"
 ** Subject to technical alterations and deviations resulting from production process without giving any notification.
 *** Contact Ayvaz sales team for the articles of 250psi version.
 **** Special designed, Braided Loop Joints with customized features are available on request.

Reduction Factors for Pressure			
Temperature °C	Reduction Factor Kp	Temperature °C	Reduction Factor Kp
20	1,00	350	0,64
100	0,85	400	0,63
150	0,81	450	0,62
200	0,77	500	0,60
250	0,71	550	0,59
300	0,68	600	0,57

Pressure reduction factor

The reduction factor is used to define the design pressure [PS] where temperatures exceed 20 °C. It compensates for the decay in material mechanical properties at elevated temperatures. The calculated pressure is lower than the nominal pressure of the standard item.

Calculation: $PS \leq PN \times Kp$



HYDROFIRE ΕΠΕ

Buildings - Industry - Marine – Waterworks
 END OF AG. PANTELEIMONOS Str. (ELEONAS)
 GR-12241 EGALEO,

Tel.: +30 210 3412 749-750 Fax: +30 210 3412 406
www.hydrofire.gr, email: info@hydrofire.gr



BRAIDED LOOP JOINTS (U-TYPE)

U-Flex, Braided Loop Joints, Welded End Connection



Available Types (Standard Versions)

U-type, Braided Loop-joint with Welded Ends		
Name	Movement in all planes	Design
U-Flex	±40mm (1,5") ±100mm (4") ±200mm (8")	175/250psi

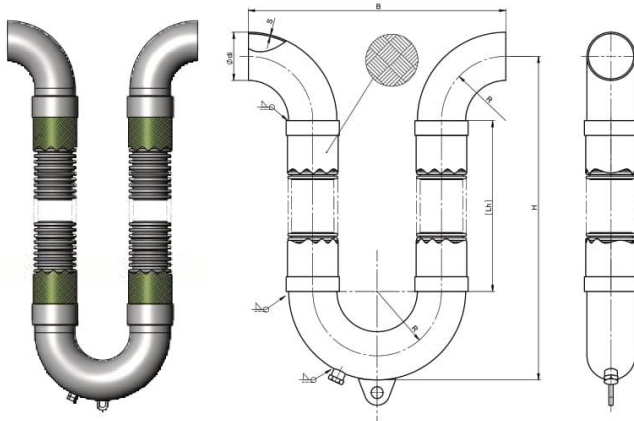

Size		Layer of Braiding		Ødi	s	R	1,5" movement (40mm)-175 PSI				4" movement (100mm)-175 PSI			
DN	inch	175 psi	250 psi				B	H	Lh	Code	B	H	Lh	Code
DN25	1"	1 ply	2 ply	33,7	2,6	38	152	380	287	702.080.301.030	254	510	417	702.080.301.035
DN32	1¼"	1 ply	2 ply	42,4	2,6	47,5	190	410	294	702.080.301.040	273	535	419	702.080.301.045
DN40	1½"	1 ply	2 ply	48,3	2,6	57	228	435	297	702.080.301.050	292	585	447	702.080.301.055
DN50	2"	1 ply	2 ply	60,3	2,9	76	304	485	303	702.080.301.060	356	635	453	702.080.301.065
DN65	2½"	1 ply	2 ply	76,1	2,9	95	380	535	307	702.080.301.070	380	715	487	702.080.301.075
DN80	3"	1 ply	2 ply	88,9	3,2	114	456	585	313	702.080.301.080	456	762	490	702.080.301.085
DN100	4"	1 ply	2 ply	114,3	3,6	152	608	715	354	702.080.301.090	608	890	529	702.080.301.095
DN125	5"	1 ply	2 ply	140	4	190	760	815	365	702.080.301.100	760	1020	570	702.080.301.105
DN150	6"	1 ply	2 ply	168,3	4,5	229	916	940	398	702.080.301.110	916	1170	628	702.080.301.115
DN200	8"	2 ply	3 ply	219	6	305	1220	1220	500	702.080.301.120	1220	1475	756	702.080.301.125
DN250	10"	2 ply	3 ply	273,0	6,3	381	1524	1400	502	702.080.301.130	1524	1702	804	702.080.301.135

* All dimensions given in the tables are in "mm"
 ** Subject to technical alterations and deviations resulting from production process without giving any notification.
 *** Contact Ayvaz sales team for the articles of 250psi version.
 **** Special designed, Braided Loop Joints with customized features are available on request.

Reduction Factors for Pressure			
Temperature °C	Reduction Factor Kp	Temperature °C	Reduction Factor Kp
20	1,00	350	0,64
100	0,85	400	0,63
150	0,81	450	0,62
200	0,77	500	0,60
250	0,71	550	0,59
300	0,68	600	0,57

Pressure reduction factor

The reduction factor is used to define the design pressure [PS] where temperatures exceed 20 °C. It compensates for the decay in material mechanical properties at elevated temperatures. The calculated pressure is lower than the nominal pressure of the standard item.

Calculation: $PS \leq PN \times Kp$



HYDROFIRE ΕΠΕ

Buildings - Industry - Marine – Waterworks
 END OF AG. PANTELEIMONOS Str. (ELEONAS)
 GR-12241 EGALEO,
 Tel.: +30 210 3412 749-750 Fax: +30 210 3412 406
 www.hydrofire.gr, email: info@hydrofire.gr



BRAIDED LOOP JOINTS (U-TYPE)

U-Flex, Braided Loop Joints, Grooved End

Available Types (Standard Versions)

U-type, Braided Loop-joint with Grooved End		
Name	Movement in all planes	Design
U-Flex	±40mm (1,5") ±100mm (4") ±200mm (8")	175/250psi

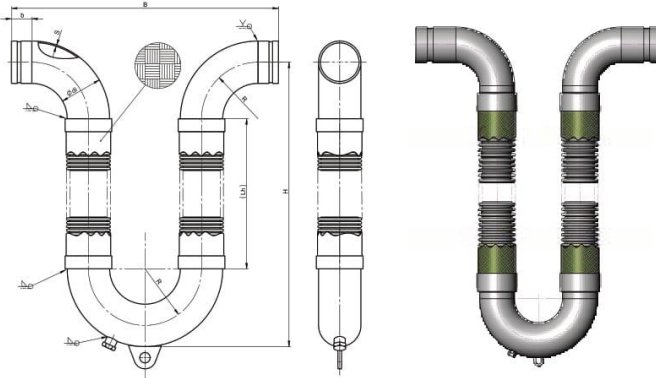
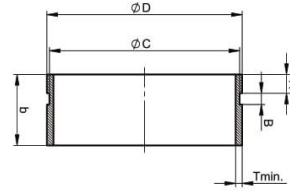

Groove Dimensions						
DN	A ±0,76	B ±0,76	T min	ØD	ØC	b
DN25	15,88	7,95	3,38	33,4	30,23	55
DN32	15,88	7,95	3,56	42,2	38,99	55
DN40	15,88	7,95	3,68	48,3	45,09	55
DN50	15,88	7,95	3,91	60,3	57,15	55
DN65	15,88	7,95	4,78	76,1	72,26	55
DN80	15,88	7,95	4,78	88,9	84,94	55
DN100	15,88	9,53	5,16	114,3	110,08	55
DN125	15,88	9,53	5,16	139,7	135,48	60
DN150	15,88	9,53	5,56	165,1	160,78	60
DN200	19,05	11,13	6,05	219,1	214,4	65
DN250	19,05	12,7	6,35	273	268,28	65

Alternative groove dimensions are also possible.

Size		Layer of Braiding		Ødi	s	R	1,5" movement (40mm)-175 PSI				4" movement (100mm)-175 PSI			
DN	inch	175 psi	250 psi				B	H	Lh	Code	B	H	Lh	Code
DN25	1"	1 ply	2 ply	33,7	2,6	38	262	380	287	702.080.307.000	364	510	417	702.080.307.005
DN32	1¼"	1 ply	2 ply	42,4	2,6	47,5	300	410	294	702.080.307.010	383	535	419	702.080.307.015
DN40	1½"	1 ply	2 ply	48,3	2,6	57	338	435	297	702.080.307.020	402	585	447	702.080.307.025
DN50	2"	1 ply	2 ply	60,3	2,9	76	414	485	303	702.080.307.030	466	635	453	702.080.307.035
DN65	2½"	1 ply	2 ply	76,1	2,9	95	491	535	307	702.080.307.040	490	715	487	702.080.307.045
DN80	3"	1 ply	2 ply	88,9	3,2	114	568	585	313	702.080.307.060	566	762	490	702.080.307.065
DN100	4"	1 ply	2 ply	114,3	3,6	152	720	715	354	702.080.307.070	718	890	529	702.080.307.075
DN125	5"	1 ply	2 ply	140	4	190	882	815	365	702.080.307.080	880	1020	570	702.080.307.085
DN150	6"	1 ply	2 ply	168,3	4,5	229	1036	940	398	702.080.307.090	1036	1170	628	702.080.307.095
DN200	8"	2 ply	3 ply	219	6	305	1350	1220	500	702.080.307.100	1350	1475	756	702.080.307.105
DN250	10"	2 ply	3 ply	273,0	6,3	381	1654	1400	502	702.080.307.110	1654	1702	804	702.080.307.115

* All dimensions given in the tables are in "mm"

** Subject to technical alterations and deviations resulting from production process without giving any notification.

*** Contact Ayvaz sales team for the articles of 250psi version.

**** Special designed, Braided Loop Joints with customized features are available on request.

Reduction Factors for Pressure			
Temperature °C	Reduction Factor Kp	Temperature °C	Reduction Factor Kp
20	1,00	350	0,64
100	0,85	400	0,63
150	0,81	450	0,62
200	0,77	500	0,60
250	0,71	550	0,59
300	0,68	600	0,57

Pressure reduction factor

The reduction factor is used to define the design pressure [PS] where temperatures exceed 20 °C. It compensates for the decay in material mechanical properties at elevated temperatures. The calculated pressure is lower than the nominal pressure of the standard item.

$$\text{Calculation: } PS \leq PN \times Kp$$



HYDROFIRE ΕΠΕ

Buildings - Industry - Marine – Waterworks
 END OF AG. PANTELEIMONOS Str. (ELEONAS)
 GR-12241 EGALIO,

Tel.: +30 210 3412 749-750 Fax: +30 210 3412 406
www.hydrofire.gr, email: info@hydrofire.gr



BRAIDED LOOP JOINTS (U-TYPE)

U-Flex, Braided Loop Joints, Threaded End



Available Types (Standard Versions)

U-type, Braided Loop-joint with EN 10226-1(R) Thread		
Name	Movement in all planes	Design
U-Flex	±40mm (1,5") ±100mm (4") ±200mm (8")	175/250psi

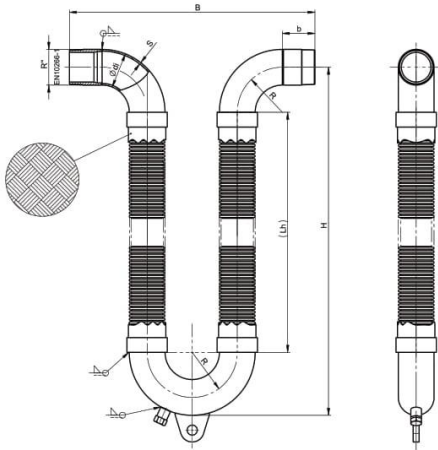

Size		Layer of Braiding		Ødi	s	R	b	1,5" movement (40mm)-175 PSI				4" movement (100mm)-175 PSI			
DN	inch	175 psi	250 psi					B	H	Lh	Code	B	H	Lh	Code
DN25	1"	1 ply	2 ply	33,7	2,6	38	55	560	330	318	702.090.305.030	747	492	455	702.090.305.035
DN32	1¼"	1 ply	2 ply	42,4	2,6	47,5	55	577	330	302	702.090.305.040	790	515	465	702.090.305.045
DN40	1½"	1 ply	2 ply	48,3	2,6	57	55	594	330	287	702.090.305.050	847	549	490	702.090.305.055
DN50	2"	1 ply	2 ply	60,3	2,9	76	55	678	370	305	702.090.305.060	925	582	500	702.090.305.065
DN65	2½"	1 ply	2 ply	76,1	2,9	95	55	789	436	350	702.090.305.070	1060	670	550	702.090.305.075
DN80	3"	1 ply	2 ply	88,9	3,2	114	55	878	480	373	702.090.305.080	1175	739	600	702.090.305.085
DN100	4"	1 ply	2 ply	114,3	3,6	152	55	1043	560	405	702.090.305.090	1358	833	650	702.090.305.095
DN125	5"	1 ply	2 ply	140	4	190	60	1230	650	450	702.090.305.100	1600	970	750	702.090.305.105
DN150	6"	1 ply	2 ply	168,3	4,5	229	60	1417	750	505	702.090.305.110	1807	1088	825	702.090.305.115

* All dimensions given in the tables are in "mm"
 ** Subject to technical alterations and deviations resulting from production process without giving any notification.
 *** Contact Ayvaz sales team for the articles of 250psi version.
 **** Special designed, Braided Loop Joints with customized features are available on request.

Reduction Factors for Pressure			
Temperature °C	Reduction Factor Kp	Temperature °C	Reduction Factor Kp
20	1,00	350	0,64
100	0,85	400	0,63
150	0,81	450	0,62
200	0,77	500	0,60
250	0,71	550	0,59
300	0,68	600	0,57

Pressure reduction factor

The reduction factor is used to define the design pressure [PS] where temperatures exceed 20 °C. It compensates for the decay in material mechanical properties at elevated temperatures. The calculated pressure is lower than the nominal pressure of the standard item.

Calculation: $PS \leq PN \times Kp$



HYDROFIRE ΕΠΕ

Buildings - Industry - Marine – Waterworks
 END OF AG. PANTELEIMONOS Str. (ELEONAS)
 GR-12241 EGALEO,
 Tel.: +30 210 3412 749-750 Fax: +30 210 3412 406
www.hydrofire.gr, email: info@hydrofire.gr



INSTALLATION INSTRUCTIONS

Motion Of Braided Loop Joints

The loop joint is designed to move in any direction making it a simple, all-in-one joint for a variety of applications. There's no limit to the seismic applications that loop joints can handle. It can even be designed with lined hose for high velocity, double-braid for high pressures, and all stainless steel construction for media compatibility.

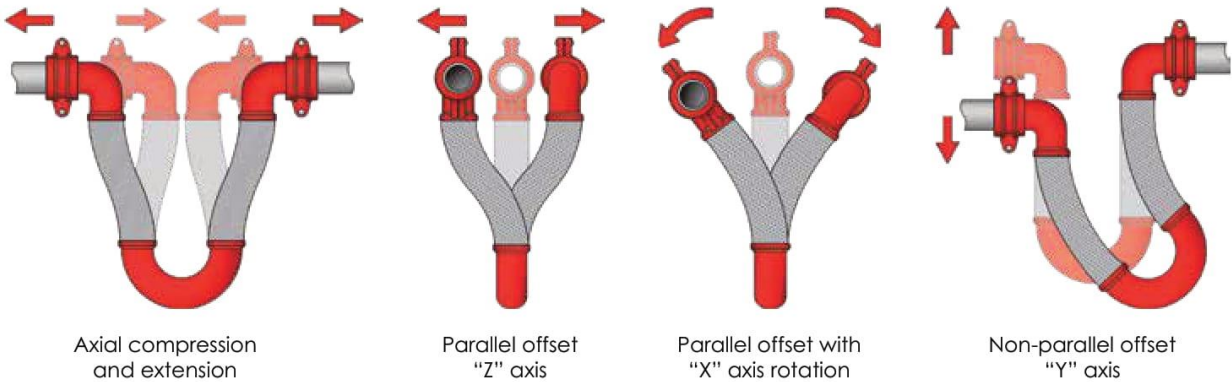

Connection Types of Loop Joints



Horizontal Connection (Hanging Down)
 Loop should hang straight down and be free to flex. Guides are required to direct movement axially.



Horizontal Connection (Straight Up)
 Support must be provided to prevent the loop from leaning. Pipe hanger rod should be loose enough to allow the 180° return to move up or down 1/4" as the loop flexes. Guides are required to direct movement of pipe axially.



Horizontal Connection
 This installation is recommended for steam. Support must be provided to prevent the loop from drooping or torquing pipe. Support must allow the 180° return, to move horizontally back and forth 1/4", as the loop flexes. Guides are required to direct movement of pipe axially.



Vertical Connection
 Loop must be supported to allow the 180° return to move horizontally back and forth 1/4" as the loop flexes. Guides are required to direct movement of pipe axially.



HYDROFIRE ΕΠΕ

Buildings - Industry - Marine – Waterworks
END OF AG. PANTELEIMONOS Str. (ELEONAS)
GR-12241 EGALEO,
Tel.: +30 210 3412 749-750 Fax: +30 210 3412 406
www.hydrofire.gr, email: info@hydrofire.gr



INSTALLATION INSTRUCTIONS

Connection Types of Loop Joints



Nested Connection

For tight pipe runs, any size or number of loops can be designed to nest inside of one another. To order, specify sequence of pipe diameters and corresponding distances between pipe centerlines.



Inside Corner Connection

Single loop joint simultaneously absorbs the thermal expansion of two pipe runs. Space-saving inside corner joint connection eliminates the need for an anchor at the corner. Guides are required to direct movement of pipe axially. Support must be provided to prevent loop joint from drooping or torquing pipe and must allow for sufficient movement.



Over-Under Connection

The loop joints expansion loop can be manufactured in a variety of configurations.



Over-Over Connection

The loop joints expansion loop can be manufactured in a variety of configurations.

Ayvaz Loop Joints Installation Instructions

1. Ayvaz loop joints can be connected to pipeline with welding ends, flanges or grooved connection mounts through rigid or flexible couplings.
2. Loop joints can be installed in any position with maximum efficiency.
3. For the Loop joint assemblies smaller than 2" (DN50), no support is required.
4. For the loop joint assemblies bigger than 2" (DN50). If the assembly is hanged down vertically, no support is required. For other type of connections, supporting operation may be done in two different ways. For the +/- 4" (100mm) movement of loop joints, a hanger rod which is 12" (300mm) or greater will allow the loop to swing properly in order to maintain the security of the assembly. In case that the loop joint is forced to be installed with hanging rod that is shorter than recommended distance above, it is suggested to use a spring hanger. Spring type of hangers may provide the required flexibility to the assembly during seismic motions.
5. Loop joint assemblies are supplied with spreader bars to prevent misalignments during installation. This bar should be removed after installation.
6. Loop joint assembly must be cleared 4" (100mm) from all around the assembly.
7. If the loop joint assembly can't meet the building's seismic separation, it is suggested to install it with the closest elbow less than 24" (600mm) from seismic separation.
8. If the loop joint assembly is to be installed in vertically upright position (180° elbow, over the pipeline), the entrapped air should be removed.