



**Victaulic® Flange Adapter for HDPE-to-Flanged Pipe
 Style 904**



1.0 PRODUCT DESCRIPTION

Available Sizes

- 3 – 8" IPS high-density polyethylene (HDPE) to 3 – 8" IPS ANSI Class 150 Flange

Pipe Material

- HDPE pipe conforming to ASTM D3035 and ASTM F714 (SDR 7 – 26)

Maximum Working Pressure

- Meets or exceeds the pressure rating of the pipe in accordance with the specifications and limitations in section 5.0 of this document

Operating Temperature

- Dependent upon pipe manufacturer rating and gasket selection
- Reference section 3.0 for gasket performance options
- Consult pipe manufacturer for pipe material performance limitations

Function

- Provides a single transition from plain end HDPE pipe to flanged piping system components
- Utilizes patented Installation-Ready™ technology to eliminate loose parts

Pipe Preparation

- For use on plain end HDPE pipe

2.0 CERTIFICATION/LISTINGS

Product designed and manufactured under Victaulic's Quality Management System, as certified by LPCB in accordance with ISO 9001:2008.

ALWAYS REFER TO ANY NOTIFICATIONS AT THE END OF THIS DOCUMENT REGARDING PRODUCT INSTALLATION, MAINTENANCE OR SUPPORT.

System No.		Location	
Submitted By		Date	

Spec Section		Paragraph	
Approved		Date	





victaulic.com

3.0 SPECIFICATIONS – MATERIAL

Housing: Ductile iron conforming to ASTM A 536, Grade 65–45–12.

Housing Coating: (specify choice)

- Orange enamel.
- Liquid bonded epoxy.
- Fusion bonded epoxy, galvanized and other coatings are available. Contact Victaulic for details.

Retaining Ring: Type 316 stainless steel.

HDPE Flange Stub Insert: (specify choice)

- SDR 11**
Plastic Pipe Institute (PPI) listed high-density polyethylene (HDPE) PE100/PE4710.
- SDR 17**
Plastic Pipe Institute (PPI) listed high-density polyethylene (HDPE) PE100/PE4710.

Coupling Gasket: (specify choice¹)

- Grade “T” Nitrile**
Nitrile (Orange stripe color code). Temperature range –20°F to +180°F/–29°C to +82°C. May be specified for petroleum products, hydrocarbons, air with oil vapors, vegetable and mineral oils within the specified temperature range, not compatible for hot dry air over +140°F/+60°C and water over +150°F/+66°C. NOT COMPATIBLE FOR USE WITH HOT WATER SERVICES OR STEAM SERVICES.
- Grade “E” EPDM**
EPDM (Green stripe color code). Temperature range –30°F to +230°F/–34°C to +110°C. May be specified for cold and hot water service within the specified temperature range plus a variety of dilute acids, oil-free air and many chemical services. UL Classified in accordance with ANSI/NSF 61 for cold +73°F/+23°C and hot +180°F/+82°C potable water service and ANSI/NSF 372. NOT COMPATIBLE FOR PETROLEUM SERVICES OR STEAM SERVICES.
- Grade “O” Fluoroelastomer**
Fluoroelastomer (Blue stripe color code). Temperature range +20°F to +300°F/–34°C to +110°C. May be specified for many oxidizing acids, petroleum oils, halogenated hydrocarbons, lubricants, hydraulic fluids, organic liquids and air with hydrocarbons. NOT COMPATIBLE FOR USE WITH HOT WATER SERVICES OR STEAM SERVICES.

¹ Services listed are General Service Guidelines only. It should be noted that there are services for which these gaskets are not compatible. Reference should always be made to the latest [Victaulic Gasket Selection Guide](#) for specific gasket service guidelines and for a listing of services which are not compatible.

NOTE

- The maximum temperature ratings shown exceed the temperature ratings for HDPE pipe. Consult individual pipe manufacturers for specific temperature limits.

Hardware:

Draw Bolts/Nuts: (specify choice²)

- Carbon steel oval neck track bolts meeting the mechanical property requirements of ASTM A449 (imperial) and ISO 898–1 Class 9.8 (M10–M16) Class 8.8 (M20 and greater). Carbon steel hex nuts meeting the mechanical property requirements of ASTM A563 Grade B (imperial – heavy hex nuts) and ASTM A563M Class 9 (metric – hex nuts). Track bolts and hex nuts are zinc electroplated per ASTM B633 ZN/FE5, finish Type III (imperial) or Type II (metric), with fluoropolymer top coat. Hardened steel washers conforming to ASTM F436 Type 3 (weathering steel).
- 3 – 4": Stainless steel oval neck track bolts meeting the mechanical property requirements of ASTM F593, Group 2 (316 stainless steel), condition CW. Stainless steel heavy hex nuts meeting the mechanical property requirements of ASTM F594, Group 2 (316 stainless steel), condition CW, with galling reducing coating. Hardened steel washers conforming to ASTM F436 Type 3 (weathering steel).
6 – 8": Stainless steel oval neck track bolts meeting the mechanical property requirements of ASTM A193 Class 2, Grade B8M. Stainless steel heavy hex nuts meeting the mechanical property requirements of ASTM A194 Grade 8M Heavy Hex, with galling reducing coating. Hardened steel washers conforming to ASTM F436 Type 3 (weathering steel).

² Optional bolts/nuts available in imperial size only



victaulic.com

4.0 DIMENSIONS

Style 904 – IPS Standard

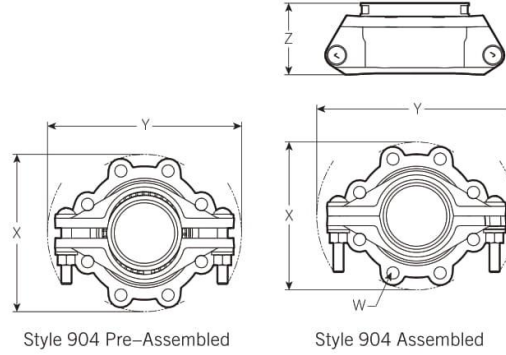

IPS Size		Draw Bolt/Nut		Flange Bolt/Nut		Dimensions						Weight
Nominal inches	Actual Outside Diameter inches mm	Qty.	Size inches mm	Qty.	Size inches mm	Pre-Assembled		Assembled				Approximate (Each) lb kg
						X inches mm	Y inches mm	W inches mm	X inches mm	Y inches mm	Z inches mm	
3	3.500 88.9	2	5/8 x 3 1/2 M16 x 89	4	5/8 M16	8.13	8.88	6.00	7.63	8.88	3.88	10.2 4.6
						207	226	152	194	226	99	
4	4.500 114.3	2	5/8 x 3 1/2 M16 x 108	8	5/8 M16	9.75	11.38	7.50	9.13	11.25	4.50	16.1 7.3
						248	289	191	232	286	114	
6	6.625 168.3	2	3/4 x 4 1/4 M20 x 108	8	3/4 M20	11.88	14.25	9.50	11.13	14.13	4.88	23.6 10.7
						302	362	241	283	359	124	
8	8.625 219.1	2	3/4 x 6 1/4 M20 x 159	8	3/4 M20	14.50	16.75	11.75	13.63	17.25	5.38	31.9 14.5
						368	425	298	346	438	137	



victaulic.com

5.0 PERFORMANCE

Style 904 – IPS Standard

Pressure Rating: joints made with Style 904 flange adapter meet the pressure rating of the HDPE pipe.

IPS Size	PE4710 HDPE Pipe ³ DR						
	7	9	11	13.5	17	21	26
Nominal Size inches	Pressure Rating psi kPa						
3 – 4	285* 1965*	250 1725	200 1380	160 1100	125 860	100 690	– –
6 – 8	285* 1965*	250 1725	200 1380	160 1100	125 860	100 690	80 550

³ HDPE pipe conforming to ASTM D3035 and F714 at 73°F/23°C. Reference plastic pipe manufacture data for derating factors at other temperatures.

* Maximum allowable pressure for ANSI Class 150lb flange. Under no circumstances shall working pressure exceed 285 psi at any temperature. Elevated temperature derate estimates can assume 333 psi maximum working pressure for DR7 pipe at 73°F/23°C.

NOTE

- Victaulic coupling gaskets have been demonstrated to seal under full (29" of Hg/3.4 kPa [absolute]) vacuum requirements. Consult the specific HDPE pipe manufacturer for their recommended limitations regarding maximum vacuum as well as the effects of temperature and pipe ovality.

5.1 PERFORMANCE

Style 904 – IPS Standard

Allowable Tensile Load (ATL): joints made with Style 904 flange adapter can sustain tensile loads noted below.

IPS Size	Allowable Tensile Load ⁴ DR						
	7	9	11	13.5	17	21	26
Nominal Size inches	lb N						
3	5146 22890	4151 18463	3473 15449	2882 12821	2327 10349	1906 8478	– –
4	8507 37839	6861 30520	5741 25539	4765 21195	3846 17108	3151 14016	– –
6	18437 82013	14871 66151	12444 55353	10327 45938	8336 37081	6829 30377	5568 24768
8	31200 138784	25200 112095	21100 93857	17500 77844	14100 62720	11574 51484	9438 41982

⁴ Allowable tensile loads shown are for straight pulling for a maximum period of one half hour at ambient temperature (68°F/20°C).



victaulic.com

5.2 PERFORMANCE

Style 904 – IPS Standard

Bend Radius: joints made with Style 904 flange adapter can sustain a bending radius as recommended by the Plastic Pipe Institute (PPI) in the Handbook of PE Pipe (2nd ed, Chapter 7, Table 4).

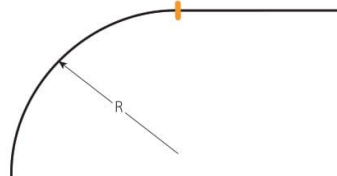

IPS Size	Minimum Recommended Bend Radius						
	DR						
Nominal Size inches	7	9	11	13.5	17	21	26
	inches mm						
3	70	70	88	88	95	95	–
	1778	1778	2223	2223	2400	2400	–
4	90	90	113	113	122	122	–
	2286	2286	2858	2858	3086	3086	–
6	133	133	166	166	179	179	225
	3366	3366	4207	4207	4543	4543	5715
8	173	173	216	216	233	233	293
	4382	4382	5477	5477	5915	5915	7442

6.0 NOTIFICATIONS

⚠ WARNING				
<ul style="list-style-type: none"> Read and understand all instructions before attempting to install, remove, adjust, or maintain any Victaulic piping products. Depressurize and drain the piping system before attempting to install, remove, adjust, or maintain any Victaulic piping products. Wear safety glasses, hardhat, and foot protection. <p>Failure to follow these instructions may cause joint failure, resulting in death or serious personal injury and property damage.</p>				